

Properties of Shapes

Maths | Year 6 | Area Overview

Introduction

In this unit, the children will draw 2D shapes to exact measurements, continue to find missing angles by measuring and calculating, and also compare and classify 2D shapes based on their properties. They revisit recognising, describing, comparing and classifying a range of 3D shapes and related shape nets and then further develop their skills by drawing and constructing their own shape nets including tabs. In addition, they consolidate being able to recognise and calculate angles around a point and on a straight line and are introduced to recognising vertically opposite angles. It also includes a brand new objective that has been introduced to KS2 relating to illustrating and naming the parts of a circle and knowing the relationship between radius and diameter.

Resources

In addition to your standard maths resources, you will need protractors, pairs of compasses, scissors, and glue.

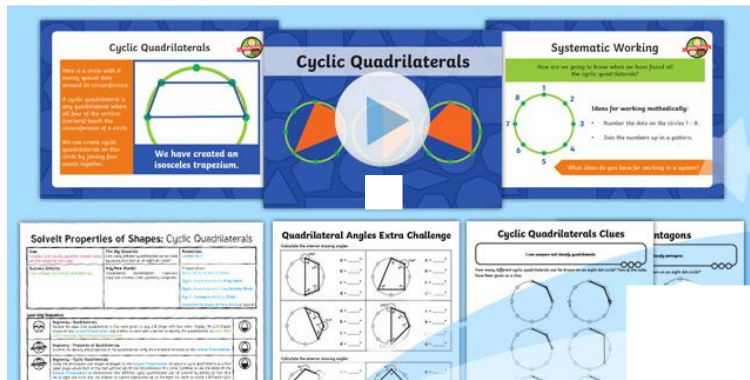

Solve Lesson Pack: Cyclic Quadrilaterals

How many different quadrilaterals can be drawn on an eight dot circle?

In this problem-solving lesson, children explore drawing cyclic quadrilaterals (quadrilaterals where each vertex lies on the circumference of a circle), working systematically to find how many different cyclic quadrilaterals are possible (not allowing rotations and reflections.) Supporting and extending differentiated activity sheets are included.

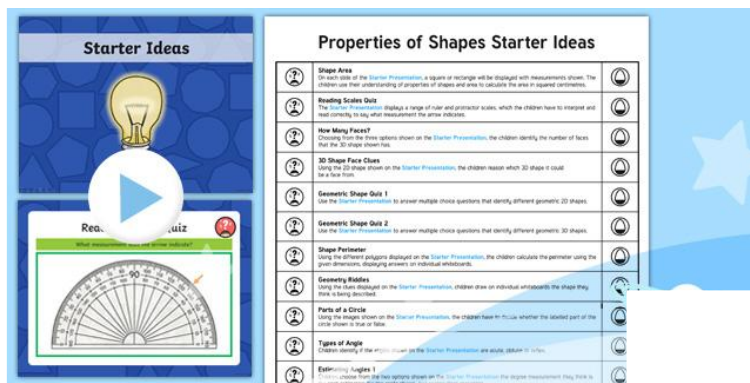

Starter Ideas

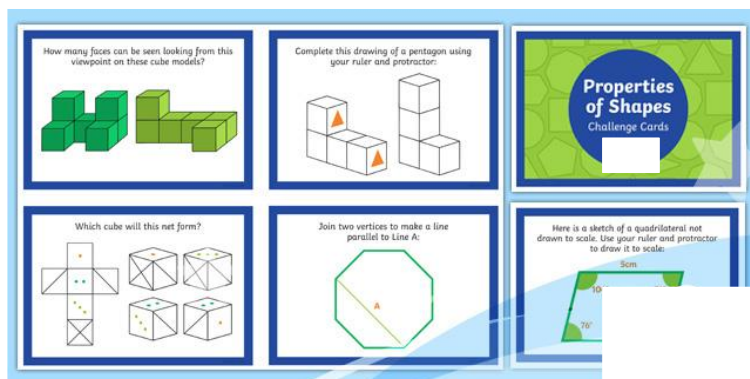

Challenge Cards

Assessment Statements

By the end of this unit...

...all children should be able to:

- use a ruler to draw a 2D shape to a given measurement;
- construct a 3D shape from a given shape net;
- compare and classify geometric shapes;
- recognise different types of angle;
- draw circle using a pair of compasses.

...most children will be able to:

- draw 2D shapes to given dimensions of length and angle;
- draw their own net of a simple 3D shape including construction tabs;
- measure and calculate unknown angles in 2D shapes and around a point or on a straight line;
- label the parts of a circle including radius and diameter.

...some children will be able to:

- confidently use a protractor to accurately draw 2D shapes to within 1° of the given dimension;
- draw their own net of more complex 3D shapes including construction tabs;
- use more complex reasoning to work out missing angles in 2D shapes and around a point or on a straight line;
- understand the relationship between radius and diameter using algebraic representation.

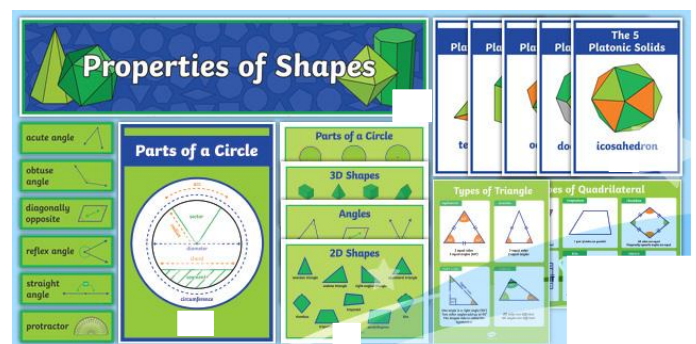

Display Pack

Lesson Breakdown

Draw 2D shapes using given dimensions and angles.

2D Shape Drawing (1): Expert 2D Shape Drawing

I can accurately draw a range of 2D shapes using the measurements given.

2D Shape Drawing (2): Champion 2D Shape Drawing

I can accurately draw a range of 2D shapes using the measurements given.

2D Shape Drawing (3): 2D Shape Reasoning

I can solve reasoning questions about drawing 2D shapes using the measurements given.

Home Learning: 2D Shape Challenge

A set of differentiated activity sheets that consolidate the skills of drawing 2D shapes to given dimensions.

Recognise, describe and build simple 3D shapes, including making nets.

3D Shapes (1): All Things 3D Shape

I can identify and describe the properties of 3D shapes and their nets.

3D Shapes (2): Drawing Shape Nets

I can draw shape nets and use them to build 3D shapes.

3D Shapes (3): 3D Shape Reasoning

I can solve reasoning questions about recognising, describing and building 3D shapes.

Home Learning: 3D Shape Challenge

A set of differentiated activity sheets that consolidate the skills of describing the properties of 3D shapes and drawing shape nets.

Compare and classify geometric shapes based on their properties and sizes and find unknown angles in any triangles, quadrilaterals and regular polygons.

Geometric Shapes (1): Triangles

I can compare, classify and find unknown angles in triangles.

Geometric Shapes (2): Quadrilaterals

I can compare, classify and find unknown angles in quadrilaterals.

Geometric Shapes (3): Polygons

I can compare, classify and find unknown angles in polygons.

Geometric Shapes (4): Polygon Reasoning

I can solve reasoning questions about comparing, classifying and finding unknown angles in polygons.

Home Learning: Polygons

A set of differentiated activity sheets that consolidate the skills of comparing and classifying geometric shapes based on their properties.

Lesson Breakdown

Illustrate and name parts of circles, including radius, diameter and circumference and know that the diameter is twice the radius.

Parts of Circles (1): Clever Circles

I can draw circles accurately using a pair of compasses and I can identify and label the parts of a circle.

Parts of Circles (2): Circle Algebra

I know that the diameter of a circle is twice the radius and can express this as algebra.

Parts of Circles (3): Circle Reasoning

I can solve reasoning questions about knowing that the diameter of a circle is twice the radius.

Home Learning: Circles

A set of differentiated activity sheets that consolidate the skills of labelling and calculating the radius and diameter of circles.

Recognise angles where they meet at a point, are on a straight line, or are vertically opposite, and find missing angles.

Angles (1): Angles at a Point

I can recognise angles where they meet at a point and find missing angles.

Angles (2): Angles on a Straight Line

I can recognise angles on a straight line and find missing angles.

Angles (3): Opposite Angles

I can recognise angles that are vertically opposite and find missing angles.

Angles (4): Angle Reasoning

I can solve reasoning questions about recognising and finding missing angles where they meet at a point, are on a straight line, or are vertically opposite.

Home Learning: Amazing Angles

A set of differentiated activity sheets that consolidate the skills of recognising and describing angles.



Amazing Angles **Answers**

Label these angles as acute, obtuse or reflex:

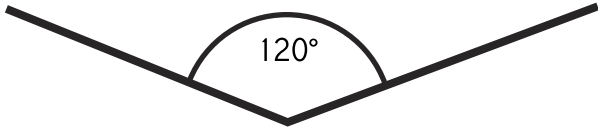

obtuse

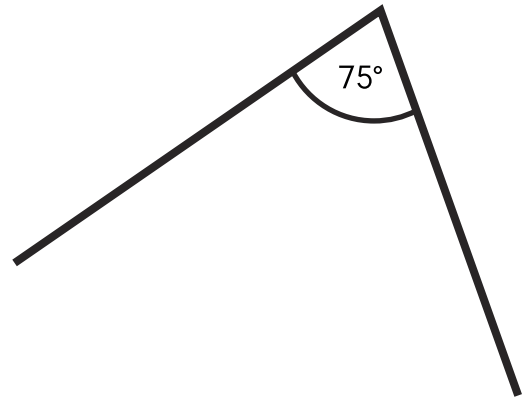

acute

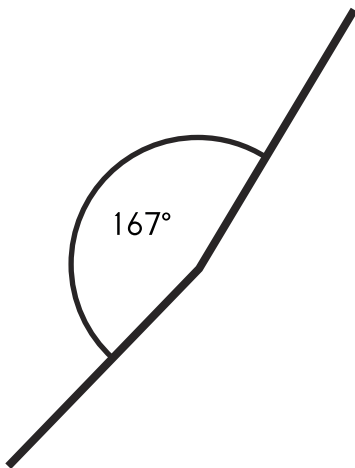

obtuse

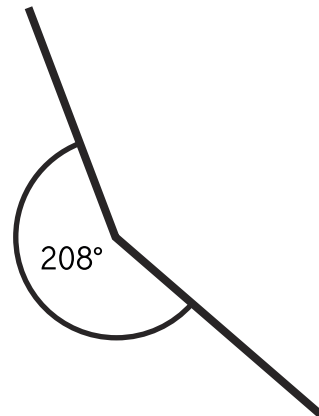

reflex

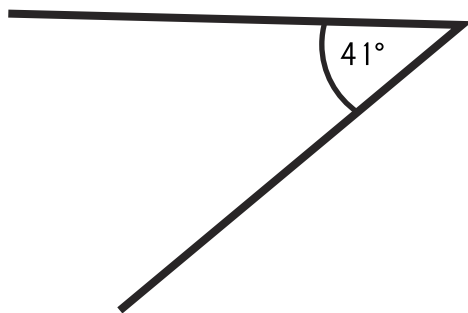

acute

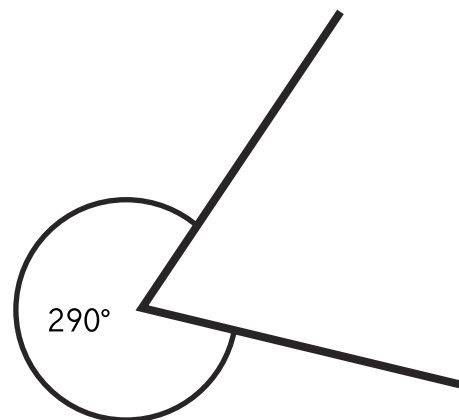

reflex



Amazing Angles Answers

Label these angles as angles around a point,
angles on a straight line or vertically opposite angles:

Around a point

On a straight line

Vertically opposite

Around a point

On a straight line

Vertically opposite

Around a point

On a straight line

Vertically opposite

Around a point

On a straight line

Vertically opposite



Amazing Angles Answers

Use your angles knowledge to solve this crossword:

Clues

Across

- The measurement of angles. (7)
- Used to measure angles. (10)
- Intersecting straight lines create vertically _____ angles. (8)
- An angle greater than 180°. (6)
- Number of degrees in a right angle. (6)

Down

- An angle of 180°. (8)
- An angle between 90° and 180°. (6)
- An angle smaller than 90°. (5)
- Angles around a _____ total 360°. (5)

						¹ d	e	g	r	e	e	² s			
												t			
			³ p	r	⁴ o	t	r	a	c	t	o	r			
		⁵ a			b							a			
		c			t		⁶ o	⁷ p	p	o	s	i	t	e	
		u			u			o				g			
		t			s			i				h			
	⁸ r	e	f	l	e	x		⁹ n	i	n	e	t	y		
								t							



Amazing Angles

Label these angles as acute, obtuse or reflex:

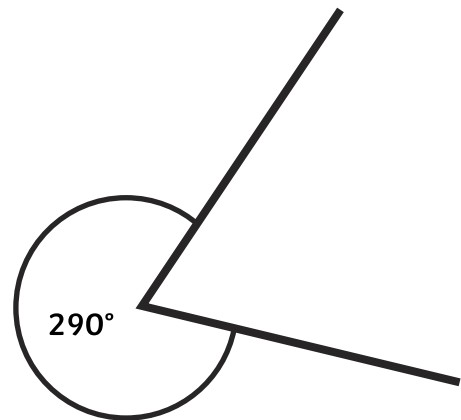
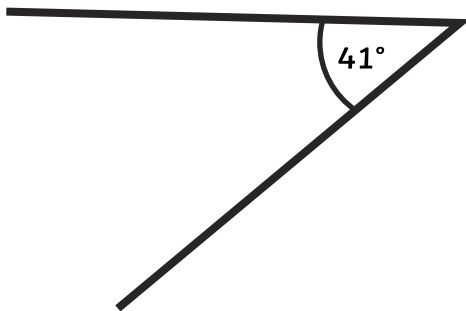
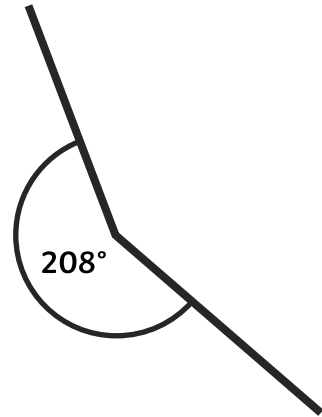
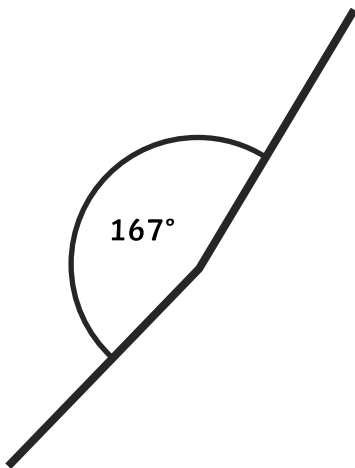
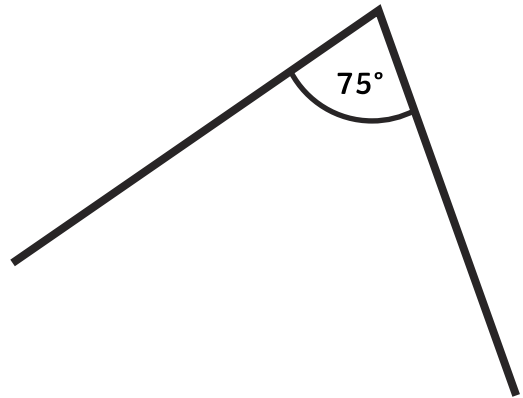



Amazing Angles

Label these angles as angles around a point, angles on a straight line or vertically opposite angles:

Around a point

On a straight line

Vertically opposite

Around a point

On a straight line

Vertically opposite

Around a point

On a straight line

Vertically opposite

Around a point

On a straight line

Vertically opposite



Amazing Angles

Use your angles knowledge to solve this crossword:

Clues

Across

1. The measurement of angles. **(7)**
3. Used to measure angles. **(10)**
6. Intersecting straight lines create vertically _____ angles. **(8)**
8. An angle greater than 180° . **(6)**
9. Number of degrees in a right angle. **(6)**

Down

2. An angle of 180° . **(8)**
4. An angle between 90° and 180° . **(6)**
5. An angle smaller than 90° . **(5)**
7. Angles around a _____ total 360° . **(5)**

